

We clean the air you breathe®

Air Shower Pass Box



Air Shower Pass Box

is for controlling the ingress of particulate contamination into cleanrooms and other controlled environments and processes. Pass Boxes are a cost effective solution as they allow materials to be transferred into the controlled environment without actual personnel movement. They may also be used to protect the external environment from egress of contamination, for example, in biological safety laboratory applications.

The unit is fully assembled and ready to install and operate when shipped. All components are designed for maximum chemical resistance and enhanced durability for long service life.

The HEPA filter provide 99.99% typical efficiency for particle size at 0.3 microns.

A disposable pre filter with 85% arrestance extends the life of the HEPA filter.

Dimension:

Standard model has stipulated below. Also customized dimension is welcomed.

Delivery:

All Pass Boxes packed with wooden crate to protect it from damage at LCL shipment.

Features and Benefits:

- Robust construction qualifies the air shower pass box for the most demanding controlled environment application.
- Electrical interlock maintains cleanroom integrity by preventing both doors from being opened at the same time.
- Jowell® Air Shower Pass Boxes use Taiwan made Duoyili® permanently lubricated, centrifugal motor with external motor designs, Selected for energy efficiency, compact design, and flat profile, the completely integrated blower assembly optimizes motor cooling, with unified rotating parts and overall components balance for smooth quiet, vibration-free operation.
- Cost Effective. Energy Efficient.
- SS 304 nozzles. SS 304 base surface
- Interlocking
- Disposable pre filter
- HEPA or ULPA Filter
- Optional UV lamp.

Application:

- Pharmaceutical
- Micro-electronics
- Semiconductors
- Spraypainting
- Food&Beverage
- Lab animal research

ULPA Filter

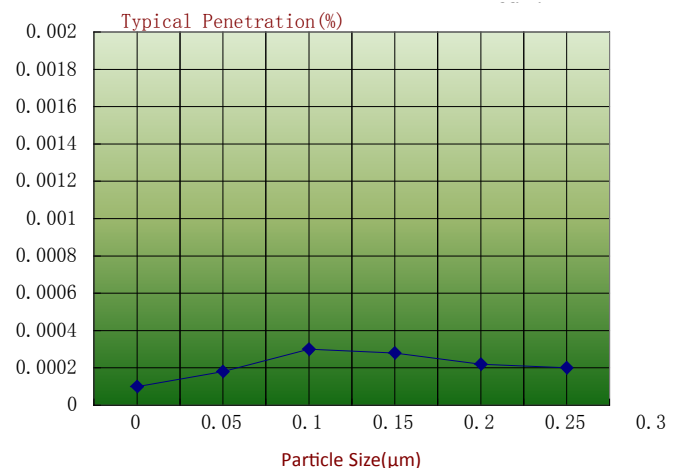

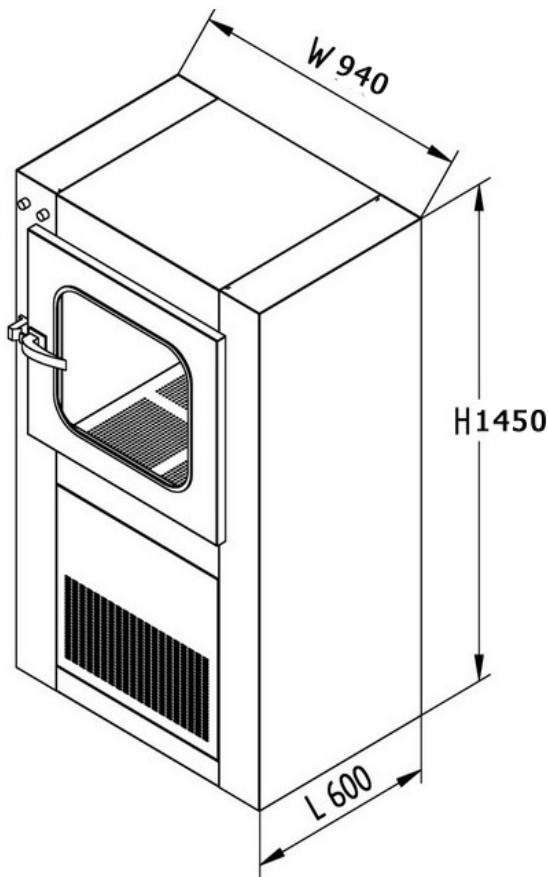

Configuration:

1. HEPA Filter
2. Nozzles
3. Interlocking door
4. Seal Stripe
5. Handle
6. Glass
7. Gemel
8. Pre Filter
9. Fan
10. Optional UV lamp
11. Power: 110V-240V 50/60Hz

Model	AS-PB-600	AS-PB-750	AS-PB-800
External Size (WxDxH) .mm	940x600x1450	1090x750x1500	1140x800x1550
Internal Size (WxDxH) . mm	600x600x600	750x750x750	800x800x800
Pre Filter Size.mm	570x290x21-1pc	745x290x21-1pc	795x290x21-1pc
HEPA Filter Size .mm	484x484x50-1pc	625x625x50-1pc	680x680x50-1pc
Fan Power	220V 50/60Hz	220V 50/60Hz	220V 50/60Hz
Airflow (m3/h)	1200	1200	1200
Noise(dB)	≤78	≤78	≤78
Fan Run (r/min)	2800	2800	2800
Nozzles	SS304 Φ38=4pcs	SS304 Φ38=4pcs	SS304 Φ38=4pcs
External Material	Powder Coated Plating	Powder Coated Plating	Powder Coated Plating
Internal Material	stainless steel	stainless steel	stainless steel
Interlock	Mechanical or Electrical	Mechanical or Electrical	Mechanical or Electrical



ZHUOWEI Purification Technology Co., Limited

No.23,ChuangLi Road, ShangSha 2nd Industrial Zone,
 ChangAn Town, Dongguan, China,523850
 Tel: +86 769 8544 0538 Fax: +86 769 8544 0539
 Email: info@zhuowei-filter.com . www.zhuowei-filter.com



© 2013 ZHUOWEI Air Filtration